

**THROUGH FRAME
INSTALLATION**

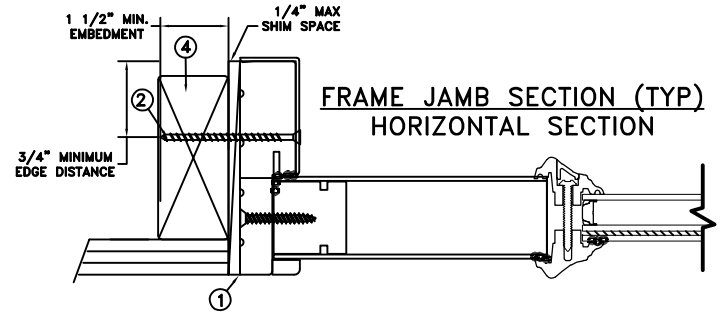

MAXIMUM FRAME	DP	IMPACT
72 x 80-5/16"	+50/-55	YES

WZ3, MISSEL LEVEL D

Installation Notes:

1. Seal flange/frame to substrate. Sill shall be set on a continuous serpentine bead of structural grade silicone caulk (typ.).
2. Use #8 PPH or greater fastener through the head & side jambs with sufficient length to penetrate a minimum of 1 1/2" into the wood framing. For 2x wood frame substrate (min. S.G. = 0.42)
3. Use #8 x 2" SFH or greater fastener through the threshold with sufficient length to penetrate a minimum of 1 1/2" into the wood framing. For 2x wood frame substrate (min. S.G. = 0.42)
4. Host structure (wood buck, masonry, steel) to be designed and anchored to properly transfer all loads to the structure. The host structure is the responsibility of the architect or engineer of record for the project of installation.

General Notes:

1. The product shown herein is designed, tested and manufactured to comply with the wind load criteria of the adopted International Building Code (IBC), the International Residential Code (IRC), the Florida Building Code (FBC) and the industry requirement for the stated conditions.
2. All glazing shall conform to ASTM E1300.
3. At minimum, glazing is 3.2mm annealed - 13.5mm airspace - 3.2mm annealed - 2.3mm PVB Interlayer by Kurraray - 3.2mm annealed insulated glass.
4. Use structural or composite shims where required.

This schedule addresses only the fasteners required to anchor the unit to achieve the rated design pressure and impact performance (where applicable) up to the size limitations noted. It is not intended as a guide to the installation process and does not address the sealing consideration that may arise in different wall conditions. For the complete installation procedure, see the instructions packaged with the unit or go to www.jeld-wen.com.

DISCLAIMER:

This drawing and its contents are confidential and are not to be reproduced or copied in whole or in part or used or disclosed to others except as authorized by JELD-WEN Inc.

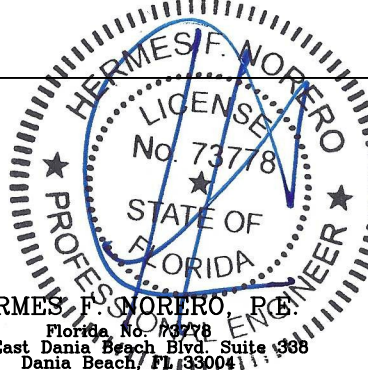

HERMES F. NORERO, P.E.
 Florida No. 73778
 398 East Dania Beach Blvd Suite 338
 Dania Beach, FL 33004

	DATE: 05/03/18	JELD-WEN 3737 LAKEPORT BLVD. KLAMATH FALLS OR, 97601 PHONE: (800) 535-3936
DRAWN BY: A. MCMILLAN	SCALE: NTS	
CHECKED BY: D. VEZO	TITLE: ARCHITECTURAL FIBERGLASS OUTSWING, FULL LITE, OXO IMPACT	
APPROVED BY: D. VEZO		
PART/PROJECT No.:	D015330	
IDENTIFIER No.:	H9984.05-301-47 R0	CAD DWG. No.:
	DRAWING NAME	REV: A
		SHEET 1 of 5

MASONRY STRAP INSTALLATION

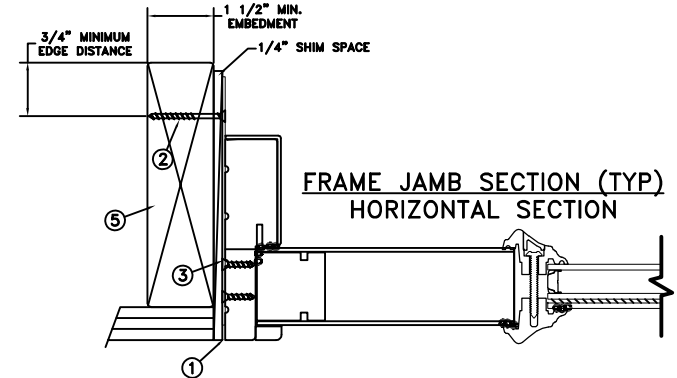
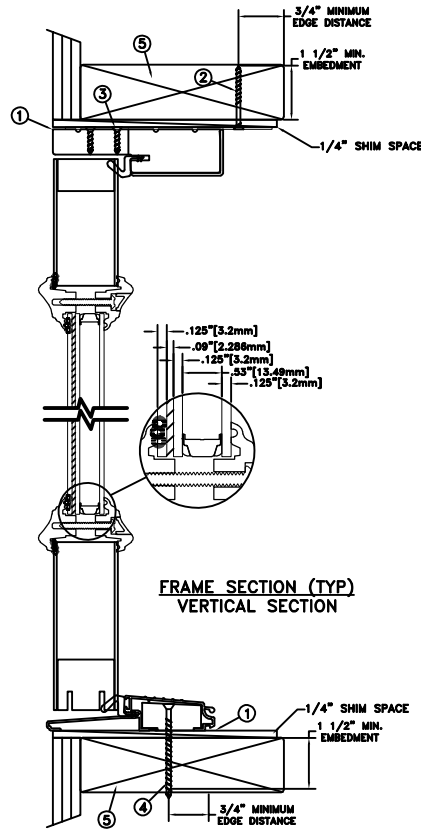
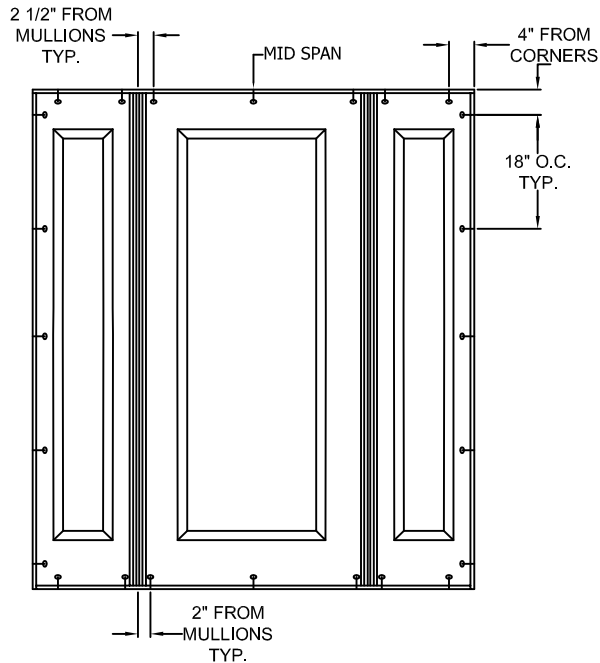

MAXIMUM FRAME	DP	IMPACT
72 x 80-5/16"	+50/-55	YES

WZ3, MISSEL LEVEL D

Installation Notes:

1. Seal flange/frame to substrate.
2. Use 2 - #8 PFH or larger fasteners through masonry strap with sufficient length to penetrate a minimum of 1 1/2" into the masonry or buck.. For concrete (min. fc = 2000 psi) or masonry substrate (CMU shall adhere to ASTM C90).
3. Use 2 - #8 PFH or larger fasteners through masonry strap into jamb without penetrating through the jamb into product causing visibility or collateral damage to product.
4. Use #8 x 2" SFH or greater fastener through the threshold with sufficient length to penetrate a minimum of 1 1/2" into the wood framing. For 2x wood frame substrate (min. S.G. = 0.42)
5. Host structure (wood buck, masonry, steel) to be designed and anchored to properly transfer all loads to the structure. The host structure is the responsibility of the architect or engineer of record for the project of installation.

General Notes:

1. The product shown herein is designed, tested and manufactured to comply with the wind load criteria of the adopted International Building Code (IBC), the International Residential Code (IRC), the Florida Building Code (FBC) and the industry requirement for the stated conditions.
2. All glazing shall conform to ASTM E1300.
3. At minimum, glazing is 3.2mm annealed - 13.5mm airspace - 3.2mm annealed - 2.3mm PVB Interlayer by Kurraray - 3.2mm annealed insulated glass.
4. Use structural or composite shims where required.

This schedule addresses only the fasteners required to anchor the unit to achieve the rated design pressure and impact performance (where applicable) up to the size limitations noted. It is not intended as a guide to the installation process and does not address the sealing consideration that may arise in different wall conditions. For the complete installation procedure, see the instructions packaged with the unit or go to www.jeld-wen.com.

DISCLAIMER:

This drawing and its contents are confidential and are not to be reproduced or copied in whole or in part or used or disclosed to others except as authorized by JELD-WEN Inc.

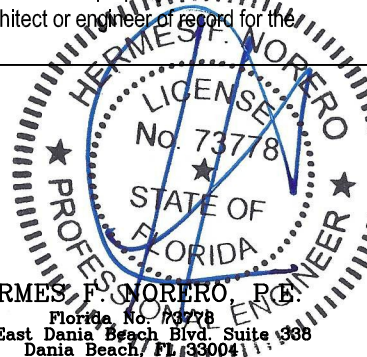

HERMES F. NORERO, P.E.
 Florida No. 73778
 398 East Dania Beach Blvd Suite 338
 Dania Beach, FL 33004

DATE: 05/03/18	3737 LAKEPORT BLVD. JELD WEN KLAMATH FALLS OR, 97601 PHONE: (800) 535-3936
DRAWN BY: A. MCMILLAN	SCALE: NTS
CHECKED BY: D. VEZO	TITLE: ARCHITECTURAL FIBERGLASS OUTSWING, FULL LITE, OXO IMPACT
APPROVED BY: D. VEZO	
PART/PROJECT No.: D015330	
IDENTIFIER No.: H9984.05-301-47 R0	CAD DWG. No.: DRAWING NAME
	REV: A SHEET 2 of 5

**THROUGH FRAME
INSTALLATION**

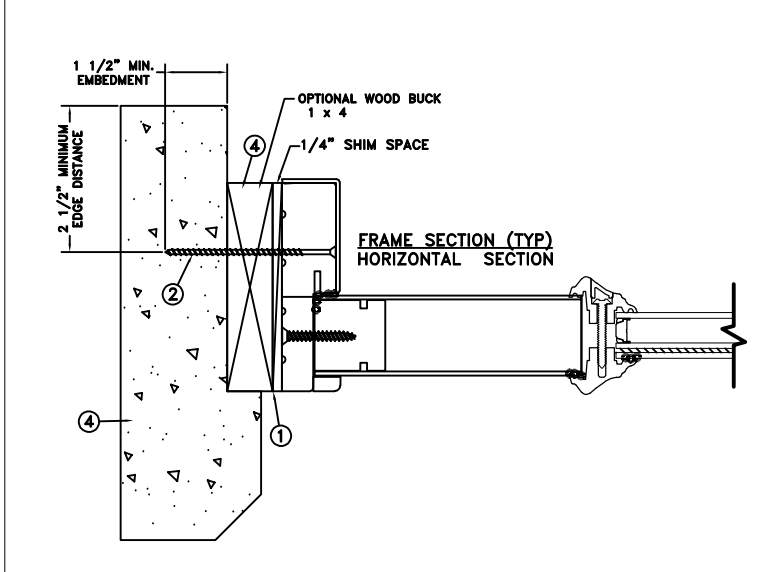
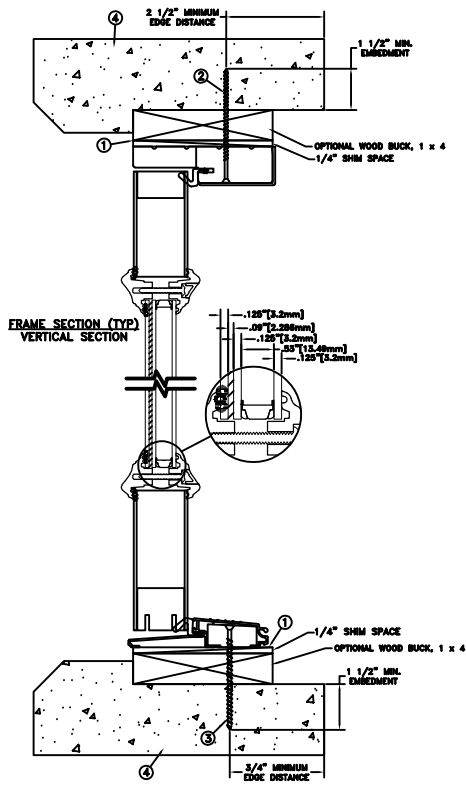
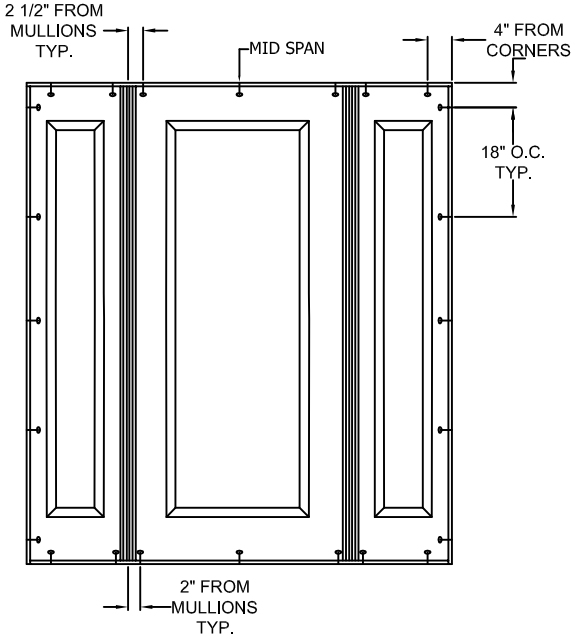

MAXIMUM FRAME	DP	IMPACT
72 x 80-5/16"	+50/-55	YES

WZ3, MISSEL LEVEL D

Installation Notes:

1. Seal flange/frame to substrate.
2. Use 3/16" Elco Tapcon or equivalent fasteners through frame with sufficient length to penetrate a minimum of 1 1/2" into concrete or masonry at each location with a 2 1/2" min. from edge distance. For concrete (min. fc = 2000 psi) or masonry substrate (CMU shall adhere to ASTM C90).
3. Use #8 SFH or greater fastener through the threshold with sufficient length to penetrate a minimum of 1 1/2" into the wood framing. For 2x wood frame substrate (min. S.G. = 0.42)
4. Host structure (wood buck, masonry, steel) to be designed and anchored to properly transfer all loads to the structure. The host structure is the responsibility of the architect or engineer of record for the project of installation.

General Notes:

1. The product shown herein is designed, tested and manufactured to comply with the wind load criteria of the adopted International Building Code (IBC), the International Residential Code (IRC), the Florida Building Code (FBC) and the industry requirement for the stated conditions.
2. All glazing shall conform to ASTM E1300.
3. At minimum, glazing is 3.2mm annealed - 13.5mm airspace - 3.2mm annealed - 2.3mm PVB Interlayer by Kurraray - 3.2mm annealed insulated glass.
4. Use structural or composite shims where required.

This schedule addresses only the fasteners required to anchor the unit to achieve the rated design pressure and impact performance (where applicable) up to the size limitations noted. It is not intended as a guide to the installation process and does not address the sealing consideration that may arise in different wall conditions. For the complete installation procedure, see the instructions packaged with the unit or go to www.jeld-wen.com.

DISCLAIMER:
This drawing and its contents are confidential and are not to be reproduced or copied in whole or in part or used or disclosed to others except as authorized by JELD-WEN Inc.

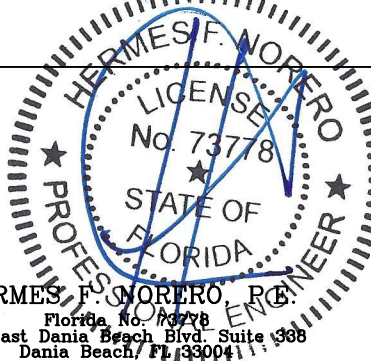

DATE: 05/03/18	3737 LAKEPORT BLVD. JELD WEN KLAMATH FALLS OR, 97601 PHONE: (800) 535-3936
DRAWN BY: A. MCMILLAN	SCALE: NTS
CHECKED BY: D. VEZO	TITLE: ARCHITECTURAL FIBERGLASS OUTSWING, FULL LITE, OXO IMPACT
APPROVED BY: D. VEZO	
PART/PROJECT No.: D015330	
IDENTIFIER No.: H9984.05-301-47 R0	CAD DWG. No.: DRAWING NAME
	REV: A SHEET 3 of 5

MASONRY STRAP INSTALLATION

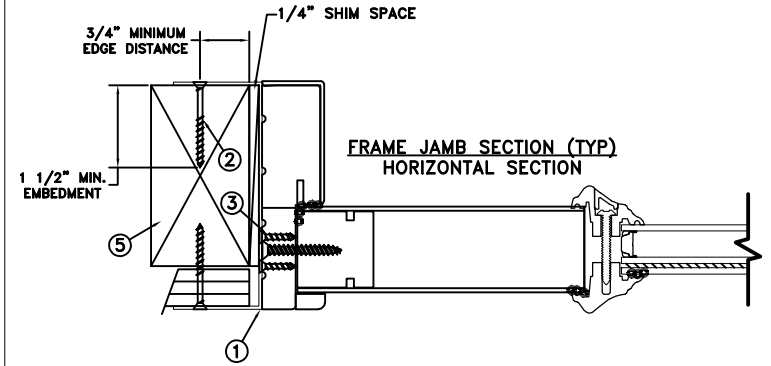
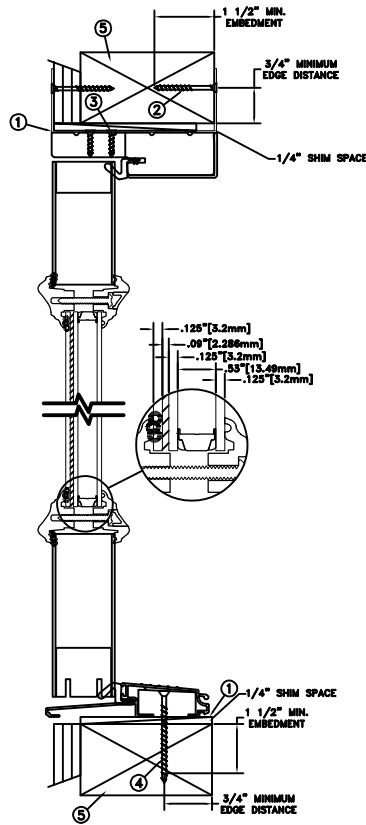
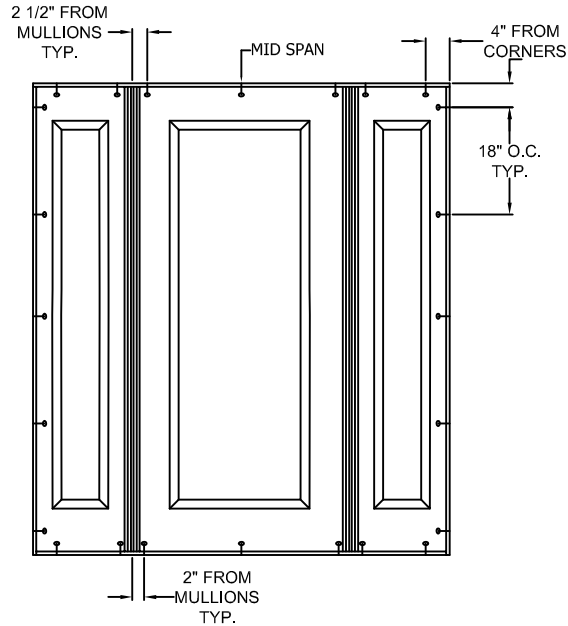

MAXIMUM FRAME	DP	IMPACT
72 x 80-5/16"	+50/-55	YES

WZ3, MISSEL LEVEL D

Installation Notes:

1. Seal flange/frame to substrate.
2. Use min. 2 - #8 PPH or larger fasteners through masonry strap with sufficient length to penetrate a minimum of 1 1/2" into the buck. Bend straps around both sides of the buck.
3. Use min. 2 - #8 PPH or larger fasteners through masonry strap into jamb without penetrating through the jamb into product causing visibility or collateral damage to product.
4. Use #8 x 2" SFH or greater fastener through the threshold with sufficient length to penetrate a minimum of 1 1/2" into the wood framing. For 2x wood frame substrate (min. S.G. = 0.42)
5. Host structure (wood buck, masonry, steel) to be designed and anchored to properly transfer all loads to the structure. The host structure is the responsibility of the architect or engineer of record for the project of installation.

General Notes:

1. The product shown herein is designed, tested and manufactured to comply with the wind load criteria of the adopted International Building Code (IBC), the International Residential Code (IRC), the Florida Building Code (FBC) and the industry requirement for the stated conditions.
2. All glazing shall conform to ASTM E1300.
3. At minimum, glazing is 3.2mm annealed - 13.5mm airspace - 3.2mm annealed - 2.3mm PVB Interlayer by Kurraray - 3.2mm annealed insulated glass.
4. Use structural or composite shims where required.

This schedule addresses only the fasteners required to anchor the unit to achieve the rated design pressure and impact performance (where applicable) up to the size limitations noted. It is not intended as a guide to the installation process and does not address the sealing consideration that may arise in different wall conditions. For the complete installation procedure, see the instructions packaged with the unit or go to www.jeld-wen.com.

DISCLAIMER:

This drawing and its contents are confidential and are not to be reproduced or copied in whole or in part or used or disclosed to others except as authorized by JELD-WEN Inc.

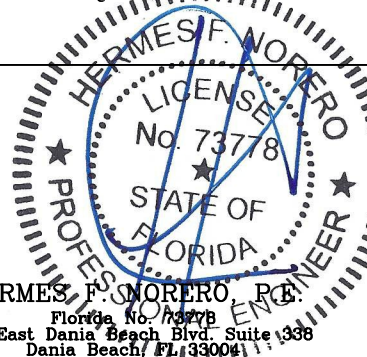

	DATE: 05/03/18	JELD-WEN 3737 LAKEPORT BLVD. KLAMATH FALLS OR, 97601 PHONE: (800) 535-3936
DRAWN BY: A. MCMILLAN	SCALE: NTS	
CHECKED BY: D. VEZO	TITLE: ARCHITECTURAL FIBERGLASS OUTSWING, FULL LITE, OXO IMPACT	
APPROVED BY: D. VEZO		
PART/PROJECT No.:	D015330	
IDENTIFIER No.:	H9984.05-301-47 R0	CAD DWG. No.:
	DRAWING NAME	REV: A
		SHEET 4 of 5

MASONRY STRAP INSTALLATION

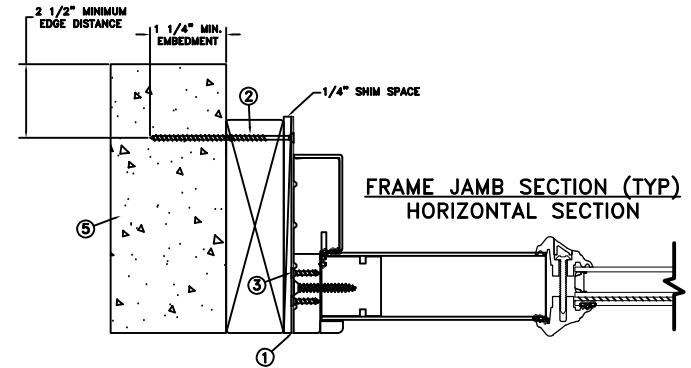
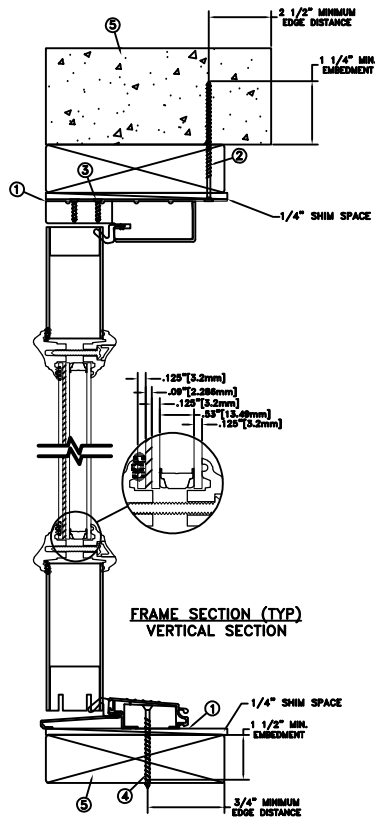
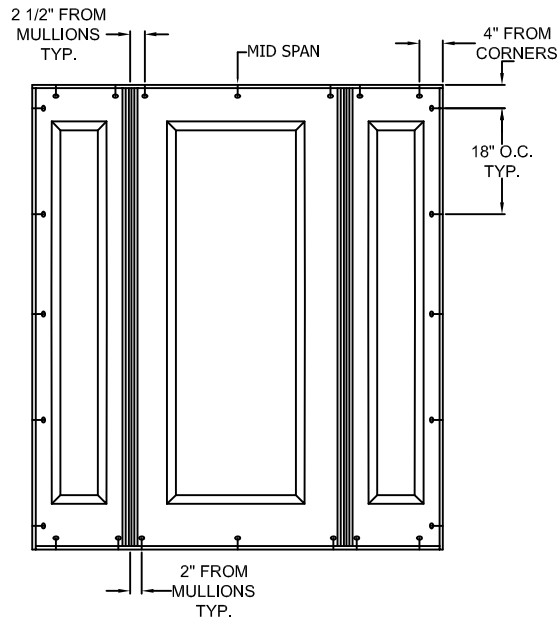

MAXIMUM FRAME	DP	IMPACT
72 x 80-5/16"	+50/-55	YES

WZ3, MISSEL LEVEL D

Installation Notes:

1. Seal flange/frame to substrate.
2. Use 3/16" Elco Tapcon or equivalent fasteners through masonry strap with sufficient length to penetrate a minimum of 1 1/2" into concrete or masonry at each location with a 2 1/2" min. from edge distance. For concrete (min. fc = 2000 psi) or masonry substrate (CMU shall adhere to ASTM C90)..
3. Use min. 2 - #8 PFH or larger fasteners through masonry strap into jamb without penetrating through the jamb into product causing visibility or collateral damage to product.
4. Use #8 x 2" SFH or greater fastener through the threshold with sufficient length to penetrate a minimum of 1 1/2" into the wood framing. For 2x wood frame substrate (min. S.G. = 0.42)
5. Host structure (wood buck, masonry, steel) to be designed and anchored to properly transfer all loads to the structure. The host structure is the responsibility of the architect or engineer of record for the project of installation.

General Notes:

1. The product shown herein is designed, tested and manufactured to comply with the wind load criteria of the adopted International Building Code (IBC), the International Residential Code (IRC), the Florida Building Code (FBC) and the industry requirement for the stated conditions.
2. All glazing shall conform to ASTM E1300.
3. At minimum, glazing is 3.2mm annealed - 13.5mm airspace - 3.2mm annealed - 2.3mm PVB Interlayer by Kurraray - 3.2mm annealed insulated glass.
4. Use structural or composite shims where required.

This schedule addresses only the fasteners required to anchor the unit to achieve the rated design pressure and impact performance (where applicable) up to the size limitations noted. It is not intended as a guide to the installation process and does not address the sealing consideration that may arise in different wall conditions. For the complete installation procedure, see the instructions packaged with the unit or go to www.jeld-wen.com.

DISCLAIMER:

This drawing and its contents are confidential and are not to be reproduced or copied in whole or in part or used or disclosed to others except as authorized by JELD-WEN Inc.

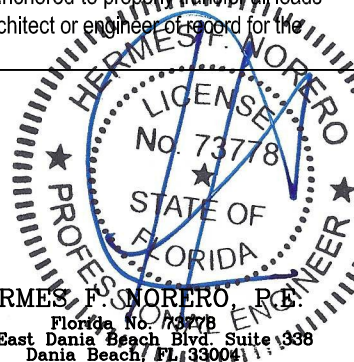

HERMES F. MORERO, P.E.
 Florida No. 73778
 398 East Dania Beach Blvd Suite 1338
 Dania Beach, FL 33004

	DATE: 05/03/18	JELD WEN 3737 LAKEPORT BLVD. KLAMATH FALLS OR, 97601 PHONE: (800) 535-3936
DRAWN BY: A. MCMILLAN	SCALE: NTS	
CHECKED BY: D. VEZO	TITLE: ARCHITECTURAL FIBERGLASS OUTSWING, FULL LITE, OXO IMPACT	
APPROVED BY: D. VEZO		
PART/PROJECT No.:	D015330	
IDENTIFIER No.:	H9984.05-301-47 R0	CAD DWG. No.:
DRAWING NAME	REV: A	SHEET 5 of 5